



G-ULTIMATE-90 ◀ 090 cm ▶



Gas cylinder cabinet G-ULTIMATE-90 model G90.205.090

light grey (RAL 7035), interior equipment with 1 x standard interior equipment gas cylinders (sheet steel galvanised and powder coated)

Order No. 30667-001-30668 4

Safe and approved storage of flammable or toxic gases in working areas – for up to 3 x 50-litre gas cylinders

Function / construction:

- **Robust construction and longevity:** body made of powder-coated sheet steel
- **No unauthorised use:** doors lockable with profile cylinder (integration in an existing locking system possible)
- **Easy alignment:** adjusting aids to compensate for uneven floor
- **Easy mounting of connecting pipes and gas fittings:** large interior height (1890 mm), many lead-through possibilities on the top of the cabinet
- **Ventilation:** integrated air ducts ready for connection (DN 75) to a technical exhaust, even ventilation inside the cabinet
- **Tested and certified:** according to the stricter GS principles

Available equipment:

- Cylinder retainer – variable installation in the cabinet, flexibly adjustable in depth, across the entire width of the cabinet
- Comfort interior equipment – complete with mounting rails, rolling ramp (L = 350 mm) with pneumatic damper, cylinder retainer and matching tension belts
- Standard interior equipment – complete with mounting rails, rolling ramp and cylinder retainer
- Lateral cylinder retainer – for two 10-litre cylinders, alternatively in height adjustable version (no tools required)



Are you looking for an appropriate storage solution for hazardous materials?

Our optimised online product configurator helps you, step by step, to find the suitable safety storage cabinet.



Take the test:
www.asecos-configurator.com



Adjusting aids
To compensate for uneven floor and an easy alignment



Gas cylinder trolley
Direct placement of gas cylinders into asecos gas cylinder cabinets



Complete ventilation
In the interior from the bottom to the top



Large interior height
Easy and effective mounting of the connecting pipes and gas equipment in the cabinet

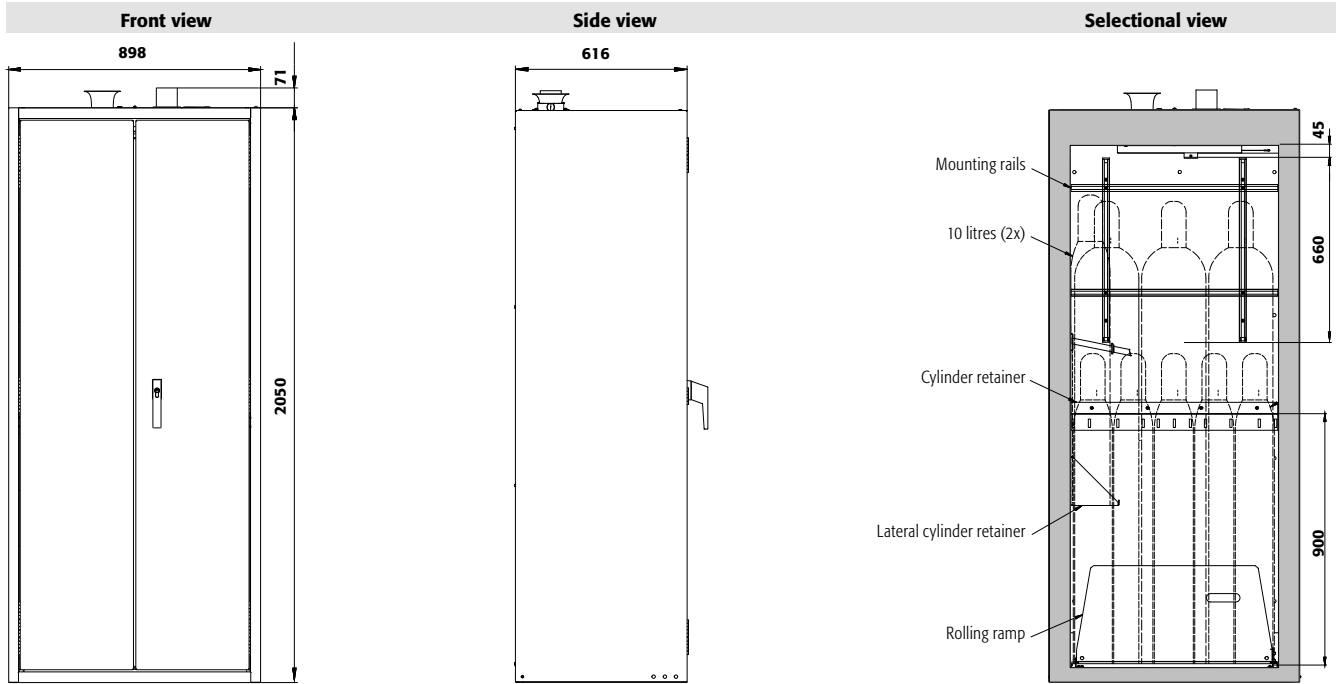

Technical data

G90.205.090

External dimensions W x D x H	mm	898 x 615 x 2050
Internal dimensions W x D x H	mm	745 x 425 x 1858
Weight without interior equip.	kg	490
Maximum load	kg	600
Distributed load	kg/m ²	752
Air change 10 times	m ³ /h	6
Diff. pressure (air change 10 times)	Pa	5
Diff. pressure (air change 10 times EK5/AK4)	Pa	5
Air change 120 times	m ³ /h	66
Diff. pressure (air change 120 times)	Pa	42
Diff. pressure (air change 120 times EK5/AK4)	Pa	147

Top view

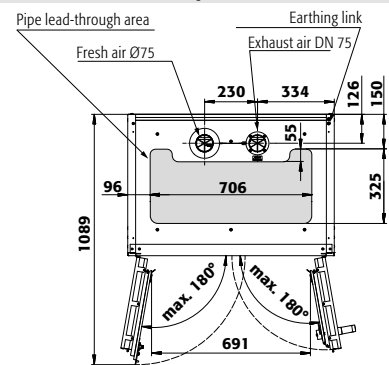

Available colours:



Order example - how to order correctly



	Model G90.205.090	Information / equipment without interior equipment	Order No. 30667
	Body colour Light grey RAL 7035 Laboratory white (sim. RAL 9016)	Door colour light grey RAL 7035 laboratory white (sim. RAL 9016)	Order No. 001 4 005 4
	Interior equipment packages (can only be ordered in combination with the cabinet) 1x standard interior equipment gas cylinders 1x comfort interior equipment gas cylinders	Material sheet steel galvanised and powder coated sheet steel galvanised and powder coated	Order No. 30668 4 30669 4
	Interior equipment	Material	W x D x H (mm) Order No.
	Shelf	sheet steel powder-coated RAL 7035	735 x 241 x 25* 75.00 30670 2
	Shelf inclined for storage of small bottles	sheet steel powder-coated RAL 7035	740 x 432 x 30* 75.00 30787 2
	Grid as storage level	steel galvanised	733 x 280 x 30 180.00 30671 4
	Securing chain in place of tension belts	steel galvanised	30672 2
	Cylinder retainer on the sidewall	sheet steel powder-coated RAL 7035	350 x 175 x 175 75.00 30647 2
	Cylinder retainer on the sidewall height adjustable without tools	sheet steel powder-coated RAL 7035	350 x 175 x 175 75.00 30648 2
	Cylinder retainer for storage of small bottles (2 u. 3 litres) on inclined shelves	sheet steel powder-coated RAL 7035	30847 2
	Cylinder retainer profile as a cylinder retainer incl. 2 tension belts and mounting material flexible mounting in height at the rear wall	sheet steel powder-coated	30650 2
	Accessories		Order No.
	Document holder DIN A5		30793 2
	Ermeto-fitting		5981 2
	Preparation for lead-through with female thread		30649 2
	Tension belt additional		13181 2
	Gas cylinder trolley, 1 x 50 litre bottle		26294 2
	Add-on kit door latching for one wing door for G-ULTIMATE-90		29818 8

* usable storage space W x D (mm) / 1) load capacity (kg)