



# BALANCE TABLE



# CONTENTS

**Standard Hood Features** **3**

**Models** **4**

**Balance Table** **5-6**

**Granite Top** **7**

**Warranty** **8**

# Balance Table Features

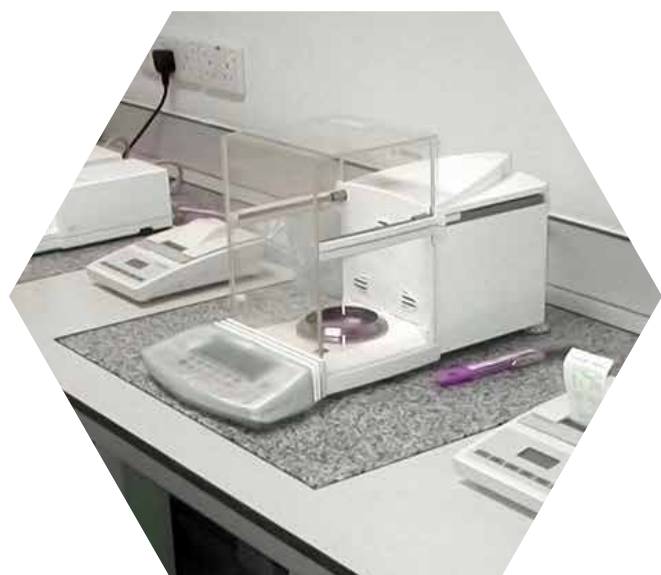

The balance table is used for analytical balances and other sensitive measuring equipment. Advancelab's Balance Tables provide superior stability for highly calibrated equipment. A heavy slab of concrete is specially mounted on a supporting construction. The supporting construction for the slab is vibration isolated from outer worktop.

- Two thickness of table top, 20mm and 60mm
- Fabricated with 75mm x 75mm epoxy powder coating galvanized steel
- An electro-galvanized steel lateral support beam adds strength and rigidity
- Superior load bearing capability and the rigidity necessary to support sensitive calibrated instrumentation
- Anti vibration leg reduce vibrations going into the floor or table
- Table top are granite surface
- Excellent acid, alkali and corrosion proof performance
- Resistance to as high as 1200°C
- Eco-friendly and space saving
- Easy to clean and maintenance

# Model

Balance Table		
MODEL	Sizes ( L x D x H )	Construction
AD0202BT	600 mm x 600mm x 900mm	<ul style="list-style-type: none"> <li>• 60mm thick granite top</li> <li>• 75mm x 75mm square tube heavy duty construction with epoxy powder coating</li> <li>• 80mm diameter anti-vibration legs</li> </ul>
AD0302BT	900 mm x 600mm x 900mm	
AD0303BT	900 mm x 900mm x 900mm	
AD0602BT	1200 mm x 600mm x 900mm	
Granite Top with 60mm Thickness		
MODEL	Sizes ( L x D x H )	Construction
AD1212-02GT	300 mm x 300mm x 60mm	
AD1818-02GT	450 mm x 450mm x 60mm	
AD2418-02GT	600 mm x 450mm x 60mm	
AD2424-02GT	600 mm x 600mm x 60mm	
Granite Top with 20mm Thickness		
MODEL	Sizes ( L x D x H )	Construction
AD1212-01GT	300 mm x 300mm x 20mm	
AD1818-01GT	450 mm x 450mm x 20mm	
AD2418-01GT	600 mm x 450mm x 20mm	
AD2424-01GT	600 mm x 600mm x 20mm	

# Balance Table

## AD0202BT

600mm x 600mm x 900mm



Front View

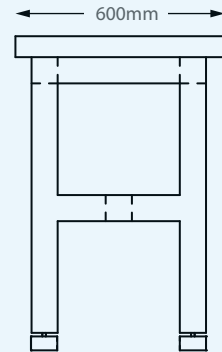

Side View

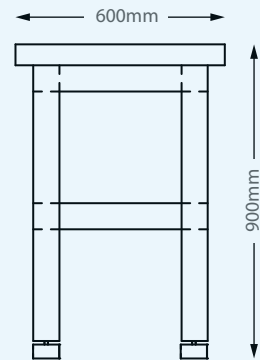

## AD0302BT

900mm x 600mm x 900mm



Front View

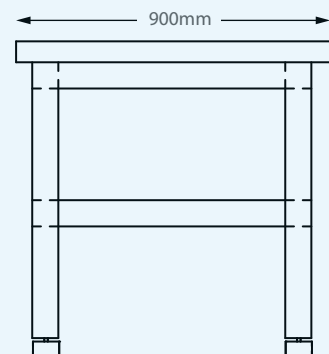

Side View

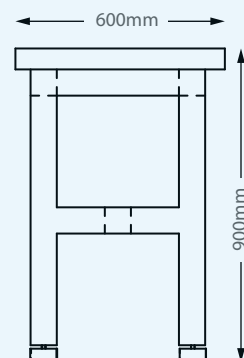

# Balance Table

## AD0303BT

900mm x 900mm x 900mm



Front View

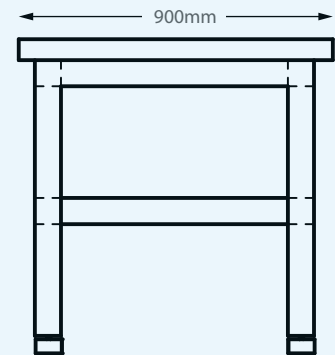

Side View

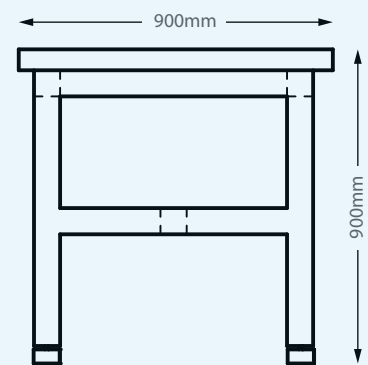

## AD0402BT

1200mm x 600mm x 900mm



Front View

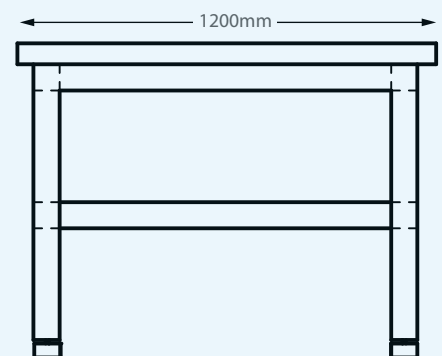

Side View

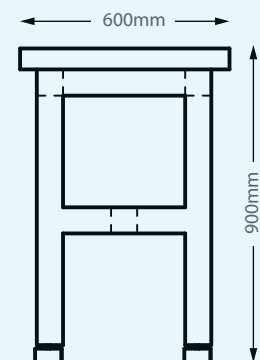

# Granite Top

## Granite 60mm

AD1212-02GT

300mm x 300mm x 60mm

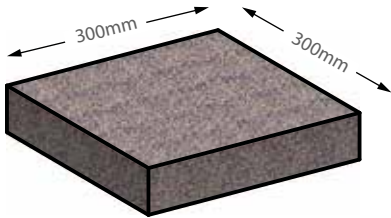

AD1818-02GT

450mm x 450mm x 60mm

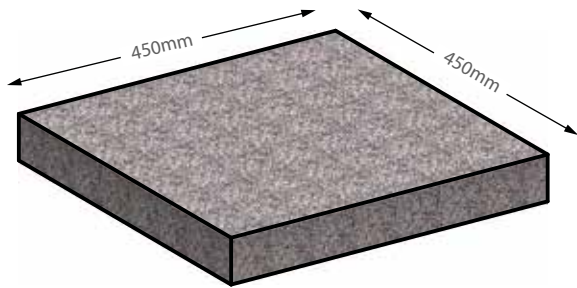

AD2418-02GT

600mm x 450mm x 60mm

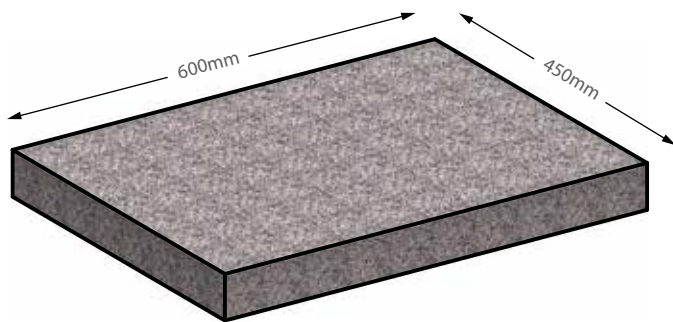

AD2424-02GT

600mm x 600mm x 60mm

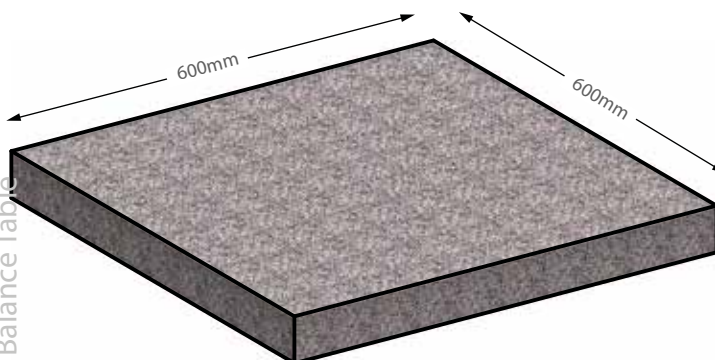

## Granite 20mm

AD1212-01GT

300mm x 300mm x 20mm

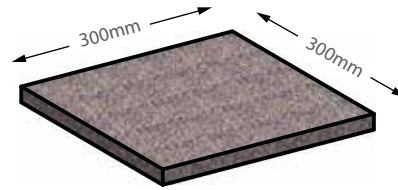

AD1818-01GT

450mm x 450mm x 20mm

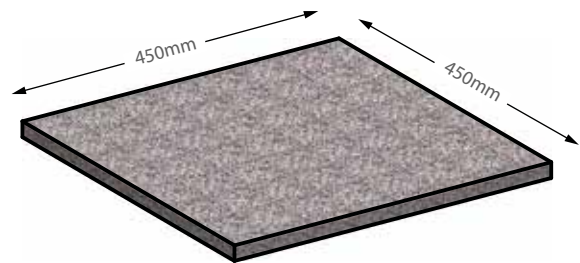

AD2418-01GT

600mm x 450mm x 20mm

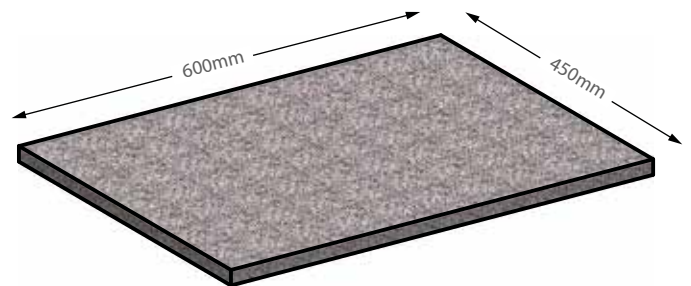

AD2424-01GT

600mm x 600mm x 20mm

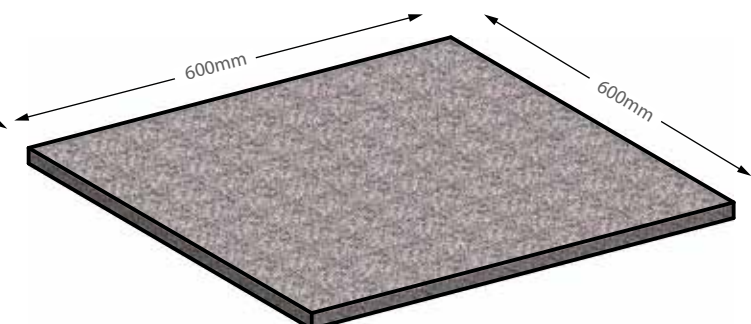

# Warranty

**Products Manufactured by Advancelab:** Advancelab(S) Pte.Ltd., warrants products that it manufactures to be free from defects for a period of 12 months for parts, commencing from the date of shipment. Advancelab's sole responsibility is to repair or replace, at its option, any part of the product that proves defective or malfunctioning during this time limit. This warranty is void if the equipment is abused or modified by the customer, is operated outside Advancelab's operating instructions or specifications, or is used in any application other than that for which it is specified. This warranty does not include routine maintenance or service procedures, breakage, shipping damage, nor damage from misuse, intentional or unintentional abuse, neglect, natural disasters, or acts of God.

**Freight Shortage or Damage:** Upon receipt of any equipment from Advancelab, customer shall immediately unpack and inspect for damage or shortage. The customer shall not accept a damaged package or a short shipment until the carrier makes a "damage or shortage" notation on both the carrier's and customer's copy of the freight bill or delivery receipt. Service title passes when the shipment is loaded, so customer is responsible for filing and collecting a freight claim. Any replacement products must be ordered and paid for separately.

Generally, customers can improve the chance of collecting on a freight claim by following these procedures:

1. Formally requesting that the carrier inspect the shipment immediately upon suspecting damage or shortage to verify condition.
2. Notifying the carrier upon discovery of concealed damage and requesting an inspection within 15 days of receipt, both in person or phone and following up via mail.
3. Keeping the shipment as intact as possible, including retaining original packaging materials and keeping the product as close to the original receiving location as possible.
4. Holding salvage for disposition by the carrier.

**All Claims:** Advancelab (S) Pte.Ltd., expressly disclaims all other warranties, expressed or implied or implied by statute, including the warranties of merchantability or fitness for intended use. Advancelab is not responsible for consequential or incidental damages arising out of the purchase or use of the products supplied by Advancelab. Advancelab is not liable for damage to facilities, other equipment, products, property or personnel of others, or of their agents, suppliers, or affiliated parties, which is caused or alleged to have been caused by products supplied by Advancelab. In any event or series of events, Advancelab's total liability for any and all damages whatsoever is limited to the lesser of the actual damages or the original invoice cost of the items alleged to have caused the damage. The customer's sole and exclusive remedy for any cause of action whatsoever is repair or replacement of the non-conforming products or refund of the actual purchase price, at the sole option of Advancelab. All claims must be made in writing within 90 days of the date the product was shipped. Any claims not made within this time limit shall be deemed waived by the customer. Advancelab is not responsible for any additional costs of repair caused by poor packaging or in-shipment damage during return.

**Warranty Returns:** All warranty returns must be authorized in advance by Advancelab and approved by writing. Unless approved in advance for good reason, all returns must be in original condition, including all manuals, and must be packaged in original packaging materials. All returned goods are to be shipped to Advancelab, freight prepaid at customer's expense.





AdvanceLab has built a rock steady reputation for solutions where most fail. Since our establishment in 2003, we have positioned ourselves as the premier facility solution provider for the scientific industry; designing, building and delivering quickly and without fuss. We have also taken our brand of expertise globally; now with exports of laboratory casework, fume hoods, laminar flow cabinets and clean booths heading to 30 countries, covering all continents.



BA  
AL  
LA  
M  
C  
E  
T  
A  
B  
L  
E

### Indonesia

PT. Advancelab Saintifik

Jl. Boulevard Raya Blok QJ 5 No. 23  
Kelapa Gading, Jakarta Utara, Indonesia  
Tel: +6221 45854570  
Fax: +6221 45854570  
Email: info-id@advancelab-global.com  
Website: www.advancelab.com.sg

### Malaysia

Advancelab Sdn Bhd

KL Office: Unit B-1-10, Block B, No. 2,  
Jalan PJU 1A/7A, Oasis Square, Ara  
Damansara, 47301 Petaling Jaya,  
Selangor Darul Ehsan, Malaysia.  
Tel: +603 7831 0188  
Fax: +603 78310588  
Email: info-my@advancelab-global.com  
Website: www.advancelab.com.sg

Johor Factory: No. 3388, Jalan  
Pekeliling Tanjung 27/2, Kawasan  
Perindustrian Indahpura, 81000  
Kulaijaya, Johor, Malaysia.  
Tel: +607 660 8877  
Fax: +607 660 8866  
Email: info-my@advancelab-global.com  
Website: www.advancelab.com.sg

### Myanmar

Advancelab Scientific & Engineering Co., Ltd

No(81/2), 7th Street, Than Thu Mar Road,  
(14/1)Quarter, South Okkalapa Township,  
Yangon, Myanmar.  
Tel: +95 (1) 572393 / +95 (9) 779753802  
Fax: +95 (1) 572393  
Email: info-mm@advancelab-global.com  
Website: www.advancelab.com.sg

### Singapore

Advancelab (S) Pte Ltd

No.52 Senang Crescent,  
Singapore 416619  
Tel: +65 6448 8255  
Fax: +65 6448 9833  
Email: info@advancelab.com.sg  
Website: www.advancelab.com.sg

### Thailand

Advancelab (Thailand) Co., Ltd.

9/28, Village No 13, Bang Ramat  
Sub-district, Taling Chan District,  
Bangkok Metropolis, Thailand  
Tel: +65 6448 8255  
Fax: +65 6448 9833  
Email: info-th@advancelab-global.com  
Website: www.advancelab.com.sg

Indonesia • Malaysia • Myanmar • Philippines • Singapore • Thailand

