



# G-ULTIMATE-90 ◀ 140 cm ▶



### Gas cylinder cabinet G-ULTIMATE-90 model G90.205.140

light grey (RAL 7035), interior equipment with 1 x standard interior equipment gas cylinders (sheet steel galvanised and powder coated)

Order No. 30641-001-30642

**Safe and approved storage of flammable or toxic gases in working areas – for up to 4 x 50-litre gas cylinders or 8 x 10-litre gas cylinders**

#### Function / construction:

- **Robust construction and longevity:** body made of powder-coated sheet steel
- **No unauthorised use:** doors lockable with profile cylinder (integration in an existing locking system possible)
- **Easy alignment:** adjusting aids to compensate for uneven floor
- **Easy mounting of connecting pipes and gas fittings:** large interior height (1890 mm), many lead-through possibilities on the top of the cabinet
- **Ventilation:** integrated air ducts ready for connection (DN 75) to a technical exhaust, even ventilation inside the cabinet
- **Tested and certified:** according to the stricter GS principles

#### Available equipment:

- Cylinder retainer – variable installation in the cabinet, flexibly adjustable in depth, across the entire width of the cabinet
- Comfort interior equipment – complete with mounting rails, rolling ramp (L = 350 mm) with pneumatic damper, cylinder retainer and matching tension belts
- Standard interior equipment – complete with mounting rails, rolling ramp and cylinder retainer
- Lateral cylinder retainer – for two 10-litre cylinders, alternatively in height adjustable version (no tools required)



### Are you looking for an appropriate storage solution for hazardous materials?

Our optimised online product configurator helps you, step by step, to find the suitable safety storage cabinet.



Take the test:  
[www.asecos-configurator.com](http://www.asecos-configurator.com)

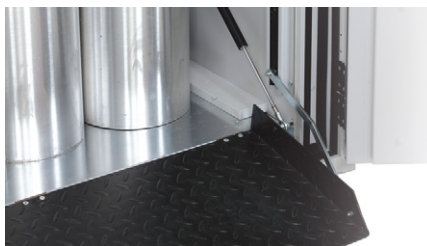

#### Comfort interior equipment

Extremely flat rolling angle, optimum slip resistance, folding out almost weightlessly

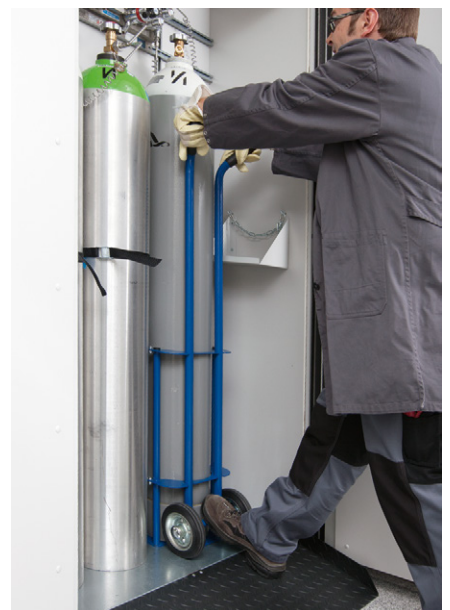

#### Gas cylinder trolley

Direct placement of gas cylinders into asecos gas cylinder cabinets



#### Complete ventilation

In the interior from the bottom to the top



#### Cylinder lock integrated in the door handle

The cabinet can be integrated into a locking system

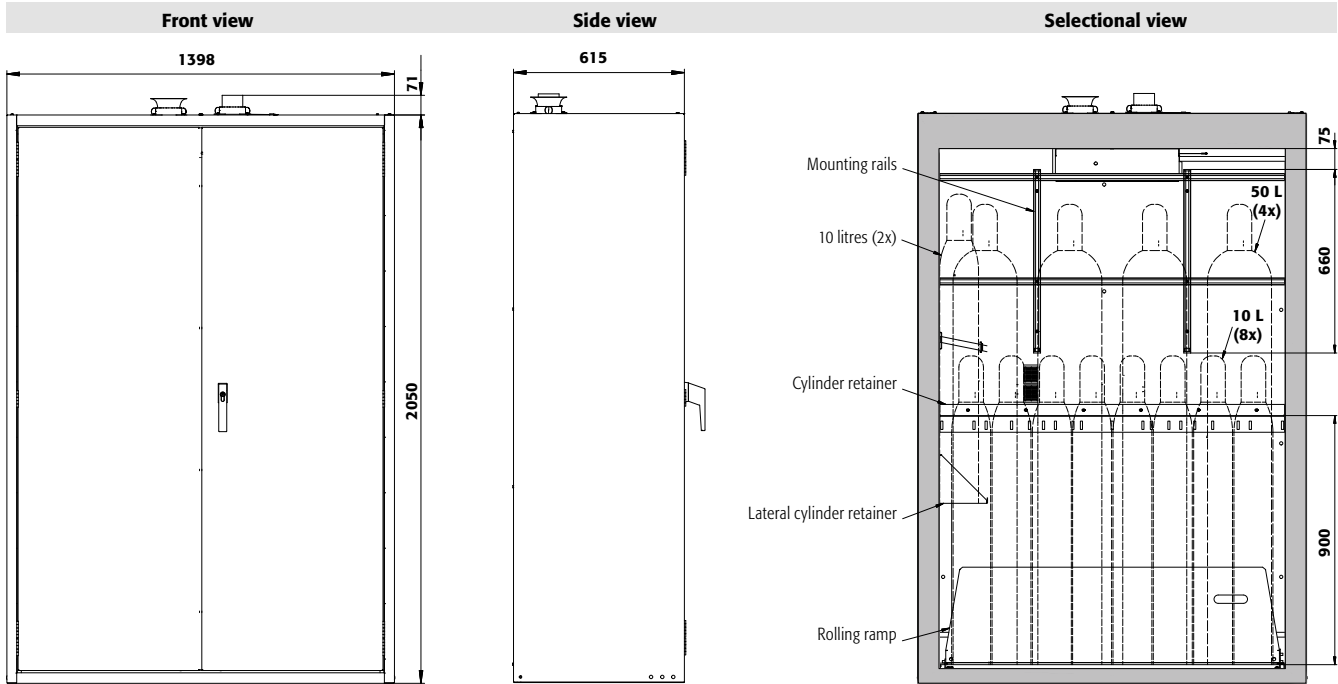

**Technical data**

**G90.205.140**

External dimensions W x D x H	mm	1398 x 615 x 2050
Internal dimensions W x D x H	mm	1245 x 400 x 1858
Weight without interior equip.	kg	690
Maximum load	kg	600
Distributed load	kg/m <sup>2</sup>	571
Air change <b>10 times</b>	m <sup>3</sup> /h	9
Diff. pressure (air change <b>10 times</b> )	Pa	5
Diff. pressure (air change <b>10 times EK5/AK4</b> )	Pa	5
Air change <b>120 times</b>	m <sup>3</sup> /h	111
Diff. pressure (air change <b>120 times</b> )	Pa	54
Diff. pressure (air change <b>120 times EK5/AK4</b> )	Pa	143

**Top view**

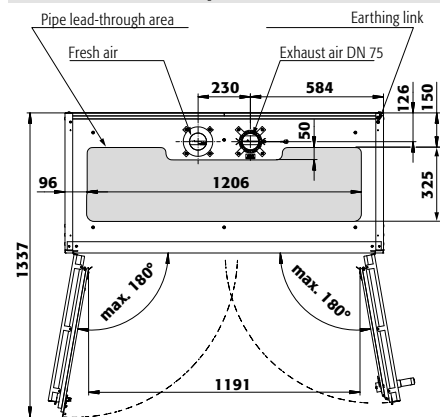

Available colours:



Order example - how to order correctly



G-LINE

	<b>Model</b> G90.205.140	<b>Information / equipment</b> without interior equipment	<b>Order No.</b> 30641
	<b>Body colour</b> Light grey RAL 7035 Laboratory white (sim. RAL 9016)	<b>Door colour</b> light grey RAL 7035 laboratory white (sim. RAL 9016)	<b>Order No.</b> 001 4 005 4
	<b>Interior equipment packages</b> (can only be ordered in combination with the cabinet)	<b>Material</b>	<b>Order No.</b>
	1x standard interior equipment gas cylinders	sheet steel galvanised and powder coated	30642 4
	1x comfort interior equipment gas cylinders	sheet steel galvanised and powder coated	30643 4
	<b>Interior equipment</b>	<b>Material</b>	<b>W x D x H (mm)</b> <b>Order No.</b>
	Shelf	sheet steel powder-coated RAL 7035	1235 x 241 x 25* 75.00 30644 2
	Shelf inclined for storage of small bottles	sheet steel powder-coated RAL 7035	1235 x 372 x 28* 75.00 30399 2
	Grid as storage level	steel galvanised	1233 x 280 x 30 180.00 30645 4
	Securing chain in place of tension belts	steel galvanised	30646 2
	Cylinder retainer on the sidewall	sheet steel powder-coated RAL 7035	350 x 175 x 175 75.00 30647 2
	Cylinder retainer on the sidewall height adjustable without tools	sheet steel powder-coated RAL 7035	350 x 175 x 175 75.00 30648 2
	Cylinder retainer for storage of small bottles (2 u. 3 litres) on inclined shelves	sheet steel powder-coated RAL 7035	30847 2
	Cylinder retainer profile as a cylinder retainer incl. 2 tension belts and mounting material flexible mounting in height at the rear wall	sheet steel powder-coated	30650 2
	<b>Accessories</b>		<b>Order No.</b>
	Document holder DIN A5		30793 2
	Ermeto-fitting		5981 2
	Preparation for lead-through with female thread		30649 2
	Tension belt additional		13181 2
	Gas cylinder trolley, 1 x 50 litre bottle		26294 2
	Add-on kit door latching for one wing door for G-ULTIMATE-90		29818 8

\* usable storage space W x D (mm) / 1) load capacity (kg)