



G-ULTIMATE-90 ◀ 060 cm ▶



Gas cylinder cabinet

G-ULTIMATE-90 model G90.205.060

light grey (RAL 7035), interior equipment with 1 x standard interior equipment gas cylinders (sheet steel galvanised and powder coated)

Order No. 30676-001-30680

Safe and approved storage of flammable or toxic gases in working areas – for up to 1 x 50-litre gas cylinders or 2 x 10-litre gas cylinders

Function / construction:

- **Robust construction and longevity:** body made of powder-coated sheet steel
- **No unauthorised use:** door lockable with profile cylinder (integration in an existing locking system possible)
- **Easy alignment:** adjusting aids to compensate for uneven floor
- **Easy mounting of connecting pipes and gas fittings:** large interior height (1890 mm), many lead-through possibilities on the top of the cabinet
- **Ventilation:** integrated air ducts ready for connection (DN 75) to a technical exhaust, even ventilation inside the cabinet
- **Tested and certified:** according to the stricter GS principles

Available equipment:

- Cylinder retainer – variable installation in the cabinet, flexibly adjustable in depth, across the entire width of the cabinet
- Comfort interior equipment – complete with mounting rails, rolling ramp (L = 350 mm) with pneumatic damper, cylinder retainer and matching tension belts
- Standard interior equipment – complete with mounting rails, rolling ramp and cylinder retainer
- Lateral cylinder retainer – for two 10-litre cylinders, alternatively in height adjustable version (no tools required)



Gas cylinder cabinet

G-ULTIMATE-90 model G90.145.060

light grey (RAL 7035), interior equipment with 1 x standard interior equipment gas cylinders (sheet steel galvanised and powder coated)

Order No. 30689-001-30691

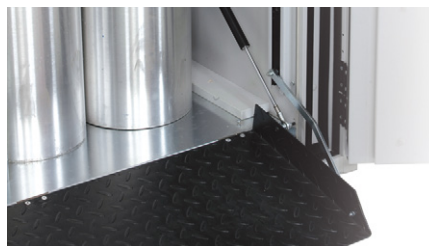

Comfort interior equipment

Extremely flat rolling angle, optimum slip resistance, folding out almost weightlessly



Cylinder lock integrated in the door handle

The cabinet can be integrated into a locking system



Gas cylinder trolley

Direct placement of gas cylinders into asecos gas cylinder cabinets



Front view

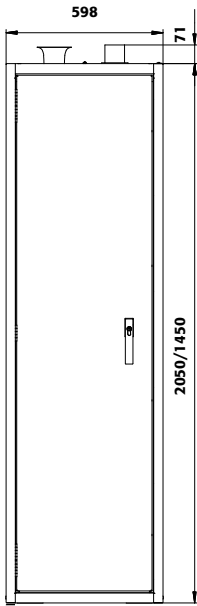

Side view

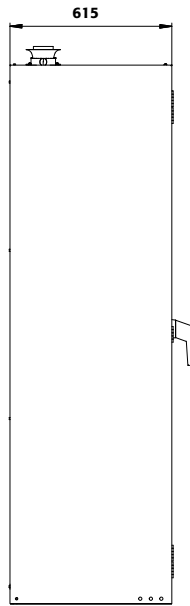

Selectional view

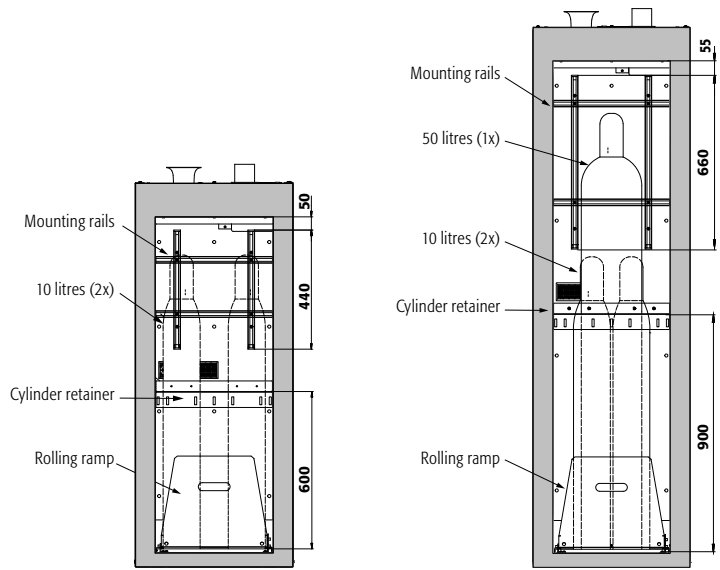

Technical data

	G90.205.060	G90.145.060
External dimensions W x D x H	mm 598 x 615 x 2050	598 x 615 x 1450
Internal dimensions W x D x H	mm 445 x 425 x 1858	445 x 425 x 1246
Weight without interior equip.	kg 365	278
Maximum load	kg 600	600
Distributed load	kg/m ² 999	909
Air change 10 times	m ³ /h 4	2
Diff. pressure (air change 10 times)	Pa 5	5
Diff. pressure (air change 10 times EK5/AK4)	Pa 5	5
Air change 120 times	m ³ /h 42	28
Diff. pressure (air change 120 times)	Pa 95	18
Diff. pressure (air change 120 times EK5/AK4)	Pa 85	42

Top view

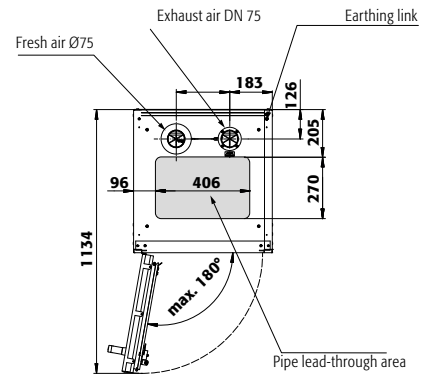

G-LINE

Model	Information / equipment	Order No.
G90.205.060	without interior equipment, left hinged	30676
G90.205.060.R	without interior equipment, right hinged	30677
G90.145.060	without interior equipment, left hinged	30689
G90.145.060.R	without interior equipment, right hinged	30690

Body colour	Door colour	Order No.
Light grey RAL 7035	light grey RAL 7035	001 4
Laboratory white (sim. RAL 9016)	laboratory white (sim. RAL 9016)	005 4

Interior equipment packages (can only be ordered in combination with the cabinet)	Material	Order No.
G90.205.060[R]		
1x standard interior equipment gas cylinders	sheet steel galvanised and powder coated	30680 4
1x comfort interior equipment gas cylinders	sheet steel galvanised and powder coated	30681 6

G90.145.060[R]		
1x standard interior equipment gas cylinders	sheet steel galvanised and powder coated	30691 4

Interior equipment	Material	W x D x H (mm)	1)	Order No.
G90.205.060[R]				
Shelf	sheet steel powder-coated RAL 7035	435 x 241 x 25*	75.00	30683 2
Shelf inclined for storage of small bottles	sheet steel powder-coated RAL 7035	440 x 432 x 30*	75.00	30788 2
Cylinder retainer for storage of small bottles (2 u. 3 litres) on inclined shelves	sheet steel powder-coated RAL 7035			30847 2
Cylinder retainer on the sidewall	sheet steel powder-coated RAL 7035	350 x 175 x 175	75.00	30647 2
Cylinder retainer on the sidewall height adjustable without tools	sheet steel powder-coated RAL 7035	350 x 175 x 175	75.00	30648 2

G90.145.060[R]		
Securing chain in place of tension belts	steel galvanised	30684 2

Accessories for all items		Order No.
Ermeto-fitting	sheet steel powder-coated	5981 2
Tension belt additional	PE black	13181 2
Preparation for lead-through with female thread	sheet steel powder-coated RAL 7035	30649 2
Gas cylinder trolley, 1 x 50 litre bottle		26294 2
Document holder DIN A5	polystyrene	30793 2
Add-on kit door latching for one wing door for G-ULTIMATE-90		29818 8